



# EZ-WRAP

## EXTERIOR BUTYL RUBBER JOINT WRAP

### What It Is

**EZ-WRAP** is an extruded butyl adhesive tape designed to provide high strength, watertight seals on properly primed concrete surfaces and concrete structure joints of any kind. The butyl compound is soft, tacky and bonded to either a plastic backing or an EPDM rubber backing. Both kinds of tape are wound in rolls on a release liner for easy application.



### Why It's Better

- High quality butyl rubber base
- Available with EPDM Rubber or HDPE Plastic backing
- All-weather performance
- Good adhesion to dry concrete, commonly specified concrete coatings, steel, glass, or painted surfaces
- Coated release paper for easy installation
- Long service life
- Primers recommended for use on damp, contaminated, or difficult surfaces

### How It Performs

**EZ-WRAP BUTYL JOINT WRAP** meets or exceeds all requirements of the following Standards, Specifications and/or Test Methods:

**ASTM C 877 (Type III) - Standard Specification for External Sealing Bands for Concrete Pipe, Manholes, and Precast Box Sections**

### Typical Applications

- Sanitary Manhole Joints
- Grade Ring Joints
- Stormwater Manhole Joints
- Irrigation and Drainage Systems
- Box Culverts
- Elliptical/Arch Pipe
- Architectural Foundations
- Underground Utility Vaults
- Stormwater Treatment Structures
- Stormwater Inlet Structures
- On-Site Treatment Tanks
- Grease Interceptors
- Wet Wells
- Concrete Bridge Spans

Press-Seal believes all information is accurate as of its publication date. Information, specifications, and prices are all subject to change without notice. Press-Seal is not responsible for any inadvertent errors. Copyright 2010.





# EZ-WRAP

## SPECIFICATION and SELECTION GUIDE

### BUTYL JOINT WRAP WITH PLASTIC BACKING

The joints and/or joining surfaces of the structures shall be sealed with a butyl-rubber-based tape. The material shall be EZ-WRAP Plastic as supplied by PRESS-SEAL GASKET CORPORATION, Fort Wayne, Indiana, or approved equal. The butyl component of the tape shall consist of 50% (min.) butyl rubber, shall contain 2% or less volatile matter, and shall be .050" thick. The backing component shall be high-density polyethylene film. A release paper may be utilized.

For manholes, the tape width shall be 6" wide. The tape shall be overlapped at least twice its width. The tape shall not be stretched during application. Primer and/or adhesive as recommended by the tape supplier shall be employed for adverse, critical, or other applications.

Testing of joints and compliance with construction requirements shall be conducted in strict conformance with the requirements of the sealant supplier.

### BUTYL JOINT WRAP WITH RUBBER BACKING

The joints and/or joining surfaces of the structures shall be sealed with a butyl-rubber-based tape. The material shall be EZ-WRAP Rubber as supplied by PRESS-SEAL GASKET CORPORATION, Fort Wayne, Indiana, or approved equal. The butyl component of the tape shall consist of 50% (min.) butyl rubber, shall contain 2% or less volatile matter, and shall be .030" thick. The backing component shall be EPDM rubber, and shall be .045" thick. A release paper may be utilized.

For manholes, the tape width shall be 6" wide. The tape shall be overlapped at least twice its width. The tape shall not be stretched during application. Primer and/or adhesive as recommended by the tape supplier shall be employed for adverse, critical, or other applications.

Testing of joints and compliance with construction requirements shall be conducted in strict conformance with the requirements of the sealant supplier.

#### EZ-WRAP PLASTIC

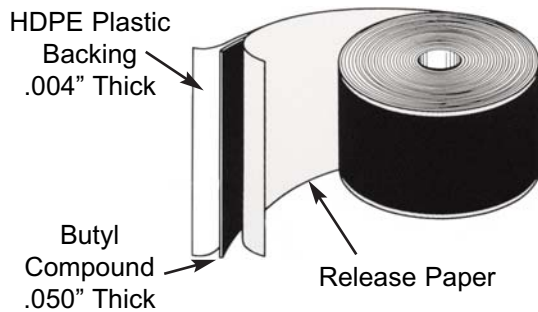

#### EZ-WRAP RUBBER

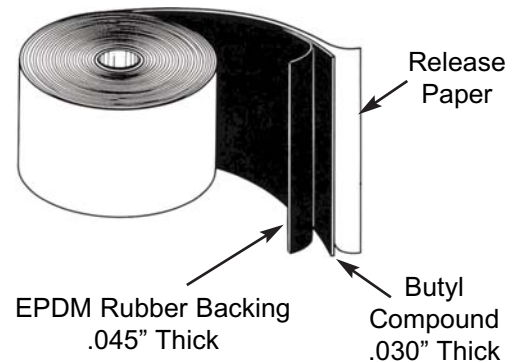

Width	Length	Backing	Part Number
6"	100'	HDPE	276.773.6
9"	100'	HDPE	276.773.9
12"	50'	HDPE	276.773.12

Width	Length	Backing	Part Number
6"	100'	EPDM	276.911.6
9"	100'	EPDM	276.511.9
12"	50'	EPDM	276.911.12

**ALSO AVAILABLE: EZ-WRAP PAKS** are pre-cut packages of EZ-WRAP designed specifically to seal manhole joints. Each **EZ-WRAP PAK** includes an easy-to-use spray adhesive and pre-cut wraps for standard 48", 60", or 72" manhole joints.

- NOTE:**
- EZ-WRAP is designed to be used with EZ-STIK No. 4 primer, or our spray adhesive
  - EZ-WRAP should not be stretched during installation

If you have any questions, please contact our Customer Service Department or your Press-Seal representative.

Press-Seal believes all information is accurate as of its publication date. Information, specifications, and prices are all subject to change without notice. Press-Seal is not responsible for any inadvertent errors. Copyright 2010.

